

HERZ STRÖMAX 4017 M

Commissioning Valve

with integral fixed orifice

Data sheet **STRÖMAX 4017 M with capillary connection**, Issue 0213

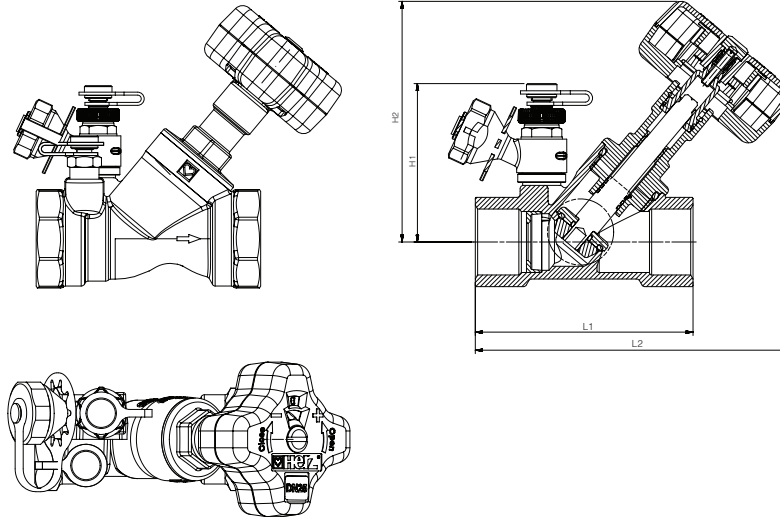

Size in mm

Fig No.:	DN	L1	L2	H1	H2	$k_{v_{max}}$	kvs
1 4017 30	15 LF	83	129	67	97	0,46	0,48
1 4017 39	15 MF	83	129	67	97	0,88	0,97
1 4017 31	15	83	129	67	97	2,00	1,95
1 4017 32	20	91	135	70	100	3,60	3,95
1 4017 33	25	100	145	73	111	6,50	7,9
1 4017 34	32	114	155	78	118	13,30	15,75
1 4017 35	40	125	183	81	143	18,50	21,5
1 4017 36	50	146	191	89	146	33,00	46,7

Manufactured to BS 7350 PN 20 Series B

The HERZ 4017 DZR combined regulating and measuring valve has an integral orifice incorporated into the valve casting. Available in sizes from DN15 to DN50, ½" to 2", with BSP female threaded ends to BS21 and manufactured to BS 7350. The valve is also available in Low Flow and Medium Flow DN15 versions. The commissioning valve has hidden regulating and locking functions with high accuracy and good repeatability.

The valve is fitted with one standard test point and one test point fitted with a capillary connection. Extended test points are available when required. A 'Micro-set' two number position indicator is fitted to the adjustment handle for recording the valve position.

Application

Can used as isolating and commissioning valve and as a partnering valve for DPCVs.

Technical data

Close the valve clockwise

Max. operating temperature

130 °C at 10 bar

Max. operating pressure

20 bar at 20 °C

Max. differential pressure on the seat

10 bar

Water purity in accordance with the OeNORM H5195 and VDI 2035 standards.

HERZ compression adapters for copper and steel pipes, allowable temperature and pressure ratings according to EN 1254-2 1998 Table 5.

HERZ plastic pipe connections max. operating temperature 95 ° C and max. operating pressure 10 bar, if approved by the pipe manufacturer.

Ammonia contained in hemp can damage brass valve bodies, EPDM gaskets can be affected by Mineral oils lubricants and thus lead to failure of the EPDM seals. Please refer to manufacturers documentation when using ethylene glycol products for frost and corrosion protection.

☑ Characteristics

Flow direction

The flow is observed according to the arrow on the body. There are no special tools required.

Installation

In any orientation.

Setting

The hand wheel position is indicated in the digital display readout on the top of the hand wheel, the valve set position can be locked easily by means of a concealed memory stop. The valve can be isolated and returned to the preset position at any time. The presetting is obscured by the hand wheel and protected against unauthorized operation.

☑ Commissioning valve 4017 M

Characteristics of the integral fixed orifice

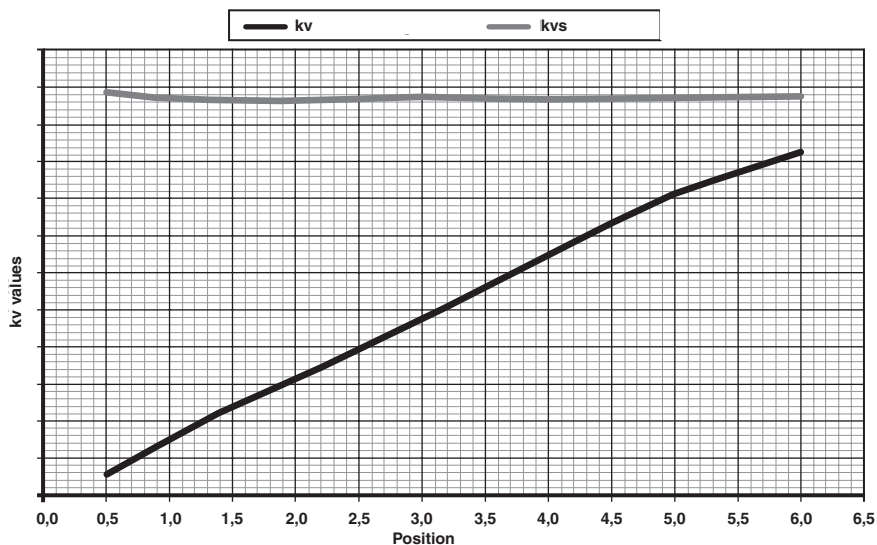

Measuring accuracy $\pm 3\%$

☑ Accessories

Presetting Marker

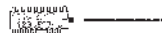

The pre-setting marker (1 6517 05) is fastened as a tag above the valve or pipe. The setting of the respective valve is marked by cutting or breaking off the teeth at the figures for full and partial turns. This permits checking and/or restoration of the original pre-setting made on the occasion of the system set-up after servicing without having to rely on documentation.

☑ Presetting Procedure

Setting and Fixing

1. Set to the desired step according to calculation (digital display on the hand wheel).
2. Remove the hand wheel locking screw, do not remove the hand wheel from the valve.
3. Screw the presetting spindle, which is now accessible, in up to the stop.
4. Screw in the hand wheel locking screw again.
5. Mark the step set at the presetting marker and attach the marker to the valve

Point 5 is not necessary for function, but is recommended. When using a differential pressure manometer, setting can be performed only on the basis of the HERZ-setting diagrams. A flowrate for the STRÖMAX 4017 M valve can only be set without specifying a pre-setting step if a measuring instrument is used. Follow the operating instructions when using a measuring computer.

☑ Sizing

The double regulating valve shall not be used less than 25% open.

☑ HERZ connection adapters for copper and steel pipes

The commissioning valves can optionally be connected to a threaded pipe or used on a calibrated copper pipe compression adapter. Compression adapters must be ordered separately.

Pipe dimension mm	8	10	12	14	15	16	18
Valve DN	15						
Adapter	1 6266 01	1 6266 01	1 6266 01	1 6266 01	1 6266 01	1 6266 01	1 6266 01
connection adapter	1 6274 18	1 6274 00	1 6274 01	1 6274 02	1 6274 03	1 6274 04	–
connection adapter	–	–	1 6276 12	1 6276 14	1 6276 15	1 6276 16	1 6276 18

Pipe dimension mm	8	10	12	14	15	16	18	22
Valve DN	20							
Adapter	1 6266 20	1 6266 20	1 6266 20	1 6266 20	1 6266 20	1 6266 20	1 6266 20	1 6266 13
connection adapter	1 6274 18	1 6274 00	1 6274 01	1 6274 02	1 6274 03	1 6274 04	–	1 6273 01
connection adapter	–	–	1 6276 12	1 6276 14	1 6276 15	1 6276 16	1 6276 18	–

Pipe dimension mm	22
Valve DN	25
Adapter	1 6266 03
connection adapter	1 6273 01

When installing soft steel or copper pipes with a pipe wall of 1 mm or less with compression unions, we recommend the use of support sleeves (order no.: 1 0674 xx). When installing plastic pipes, suitable calibration tools are needed. Please refer to our instruction manual. For proper installation use silicone oil to lubricate the thread of the locking nut or olive screw as well as the olive.

☑ Plastic pipe connections

The commissioning valves can be used in systems with plastic pipes. Plastic pipe connections are fitted to special adapters.

Pipe dimension mm	14 x 2	16 x 2	16 x 2,2	17 x 2	17 x 2,5	18 x 2	18 x 2,5	20 x 2	20 x 2,5	20 x 3,5
Valve DN	15									
Adapter	1 6266 01	1 6266 01	1 6266 01	1 6266 01	1 6266 01	1 6266 01	1 6266 01	1 6266 01	1 6266 01	1 6266 01
Pipe connection	1 6098 02	1 6098 03	1 6098 12	1 6098 04	1 6098 05	1 6098 07	1 6098 06	1 6098 08	1 6098 11	1 6098 10

Pipe dimension mm	14 x 2	16 x 2	16 x 2,2	17 x 2	17 x 2,5	18 x 2	18 x 2,5	20 x 2	20 x 2,5	20 x 3,5
Valve DN	20									
Adapter	1 6266 20	1 6266 20	1 6266 20	1 6266 20	1 6266 20	1 6266 20	1 6266 20	1 6266 20	1 6266 20	1 6266 20
Pipe connection	1 6098 02	1 6098 03	1 6098 12	1 6098 04	1 6098 05	1 6098 07	1 6098 06	1 6098 08	1 6098 11	1 6098 10

Pipe dimension mm	16 x 2	20 x 2	25 x 3,5	26 x 3
Valve DN	25			
Adapter	1 6266 03	1 6266 03	1 6266 03	1 6266 03
Pipe connection	1 6098 11	1 6098 12	1 6198 00	1 6198 01

- ☑ **Spare parts**
- | | | |
|-----------|-----|---|
| 1 0284 01 | 1/4 | test point for HERZ circuit control valve, blue cap (return) |
| 1 0284 02 | 1/4 | test point for HERZ circuit control valve, red cap (flow) |
| 2 0284 01 | 1/4 | test point for HERZ circuit control valve (for drinking water), blue cap (return) |
| 2 0284 02 | 1/4 | test point for HERZ circuit control valve (for drinking water), red cap (flow) |
| 1 0284 11 | 1/4 | test point for HERZ circuit control valve, extended model, blue cap (return) |
| 1 0284 12 | 1/4 | test point for HERZ circuit control valve, extended model, red cap (flow) |
| 1 0284 22 | 1/4 | HERZ test point with draining function, red cap (flow) |
| 1 0284 21 | 1/4 | HERZ test point with draining function, blue cap (return) |
| 1 0284 03 | 1/4 | test point with capillary connection, brass version, blue cap (return) |
| 1 0284 04 | 1/4 | test point with capillary connection, brass version, red cap (flow) |

☑ Warning notices

The valves must be installed for the correct application using clean fittings.

Please avoid introducing any dirt into the system when installing the valve.

Screw the pipe into the valve and with a suitable assembly tool taking care to support the valve during tightening to avoid distortion.

The installation of the valve should be carried out by competent trained professionals. Sealing materials should be used to seal the connection between the pipe and the valve. If space is restricted, the valve upper part can be removed during installation. When reassembling the upper part excessive tightening of the valve upper part is not necessary as the upper part is sealed with an O ring.

☑ Test points

Two test points are fitted on the same side of the valve and factory sealed. This arrangement ensures the best accessibility in any position and optimum connection of measuring instruments.

☑ Other Versions

4117 M	DN 15 - 80	Strömax-M, Double Regulating Valves, inclined model with test points
4117 R	DN 15 - 80	Strömax-R, Double Regulating Valves, inclined model
4117 U	DN 15 - 50	Strömax-U, Double Regulating Valves, inclined model
4117 MW	DN 15 - 50	Strömax-MW, Double Regulating Valves for drinking water, inclined model with test points
4117 RW	DN 15 - 50	Strömax-RW, Double Regulating Valves for drinking water, inclined model
4217 GM	DN 15 - 80	Strömax-GM, Double Regulating Valves, screw-down model with test points
4217 GR	DN 15 - 80	Strömax-GR, Double Regulating Valves, screw-down model
4217 GM-BS	DN 15 - 50	Strömax-GM-BS, Double Regulating Valves, screw-down model with test points
4216 MS	DN 15 - 20	Strömax-MS, Regulating Valve for manual adjustment, screw-down model with test point
4000	DN 15 - 50	HERZ-Metering Stations with two test points
4218 GMF	DN 25 - 80	Strömax-GMF, Double Regulating Valves, flanged version with test points
4218 GF	DN 50 - 300	Strömax-GF, Double Regulating Valves, flanged version with test points
4219	DN 50 - 300	HERZ-Butterfly Valves, flanged version, GJL
4000 + 4117-R		HERZ-Metering Station + STRÖMAX-R- Double Regulating Valve
4000 + 4217-GR		HERZ-Metering Station + STRÖMAX-GR- Double Regulating Valve
4000 F + 4218 GMF		HERZ-Stainless Steel Orifice Plates + STRÖMAX-GMF Double Regulating Valves, flanged version with test points
4000 F + 4218 GF		HERZ-Stainless Steel Orifice Plates + STRÖMAX-GF Double Regulating Valves, flanged version with test points
4000 F	DN 65 - 300	HERZ-Stainless Steel Orifice Plates
4017 R	DN 15 - 50	Strömax-R, Double Regulating Valves, inclined model



Measuring

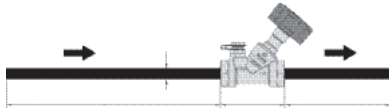

Fixed orifice double regulating valves must always be installed with a minimum of 10 pipe diameters of straight pipe, without intrusion, upstream of the orifice plate. Downstream of the valve a minimum of 5 pipe diameters of straight pipe are required.

Correction factors for glycol mixtures with measurements with HERZ-measuring computer

Temperature, °C	Ethylene glycol 34%, (Factor)	Ethylene glycol 40%, (Factor)	Ethylene glycol 44%, (Factor)
-20	1.98	2.133	2.235
-15	1.833	1.9908	2.096
-10	1.737	1.8738	1.965
-5	1.649	1.7702	1.851
0	1.567	1.6744	1.746
5	1.482	1.5876	1.658
10	1.412	1.505	1.567
15	1.342	1.4254	1.481
20	1.281	1.3554	1.405
25	1.226	1.2956	1.342
30	1.163	1.2284	1.272
35	1.123	1.1848	1.226
40	1.079	1.136	1.174
45	1.04	1.0928	1.128
50	1	1.0528	1.088
55	0.974	1.0214	1.053
60	0.947	0.9938	1.025
65	0.926	0.9714	1
70	0.912	0.9528	0.98
75	0.893	0.9332	0.96
80	0.884	0.9242	0.951

$$dP_R / f = dP_{\text{Display}}$$

$$Q_R / \sqrt{f} = Q_{\text{Display}}$$

dP_R
 dP_{Display}
 Q_R
 Q_{Display}
 f

Real differential pressure
 Differential pressure on the display
 Real flow rate
 Flow rate on the display
 Factor from the table above

Scheme: Hydraulic balance

The following points must be considered before commissioning:

1. Measure the flow in all terminals with the main branch valve fully open and the control valves disabled and fully open.
2. For each terminal calculate the flow ratio λ where: $\lambda = \text{measured flow} / \text{designed flow}$.
3. Identify the terminal with the lowest flow ratio λ_{min} , this is referred to as the index unit. If the terminals have the same pressure loss for design flow, terminal 4 will normally have the lowest flow ratio since it receives the smallest differential pressure. However, if the terminals have different pressure drops, any valve could potentially be used as an index valve.
4. Use the balancing valve (B), on terminal 4 of the branch as the reference valve.
5. Adjust the reference valve so that $\lambda_4 = \lambda_{\text{min}}$. lock valve 4B to this setting. Connect flow measuring instrument for continuous flow.
6. Set valve 3B so that $\lambda_3 = \lambda_4 + (5 \text{ to } 10 \%)$. The percentage increase ensures that the system is not over regulated. This step also causes a change in the flow ratio λ_4 .
7. If the setting of the valve (3B), changes the flow in the reference valve by more than 5%, this index valve must be adjusted so that with the commissioning valve (3B) is approximately equal within 5 - 10%.
8. The points 6 and 7 must be repeated until all terminals have been set.
9. Note: When 1B is adjusted, the flow ratio λ_4 , λ_2 and λ_3 remain proportionally equal to 4. This means that the valves B2, B3 and B4 are balanced relative to each other. It is also the reason why the index terminal is used as a reference valve.

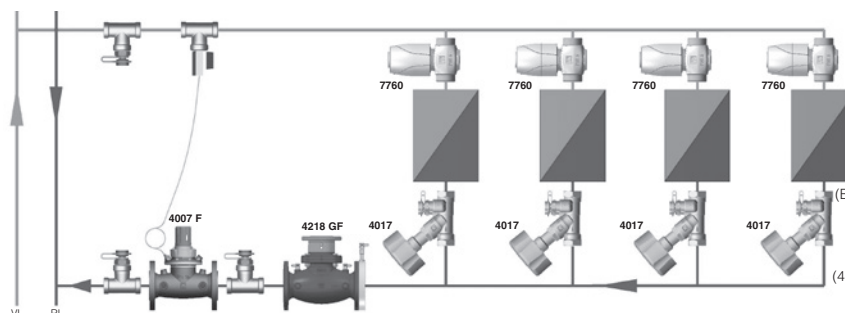

HERZ- flow data - flow signal

STRÖMAX 4017 M

Fig. No. **4017**

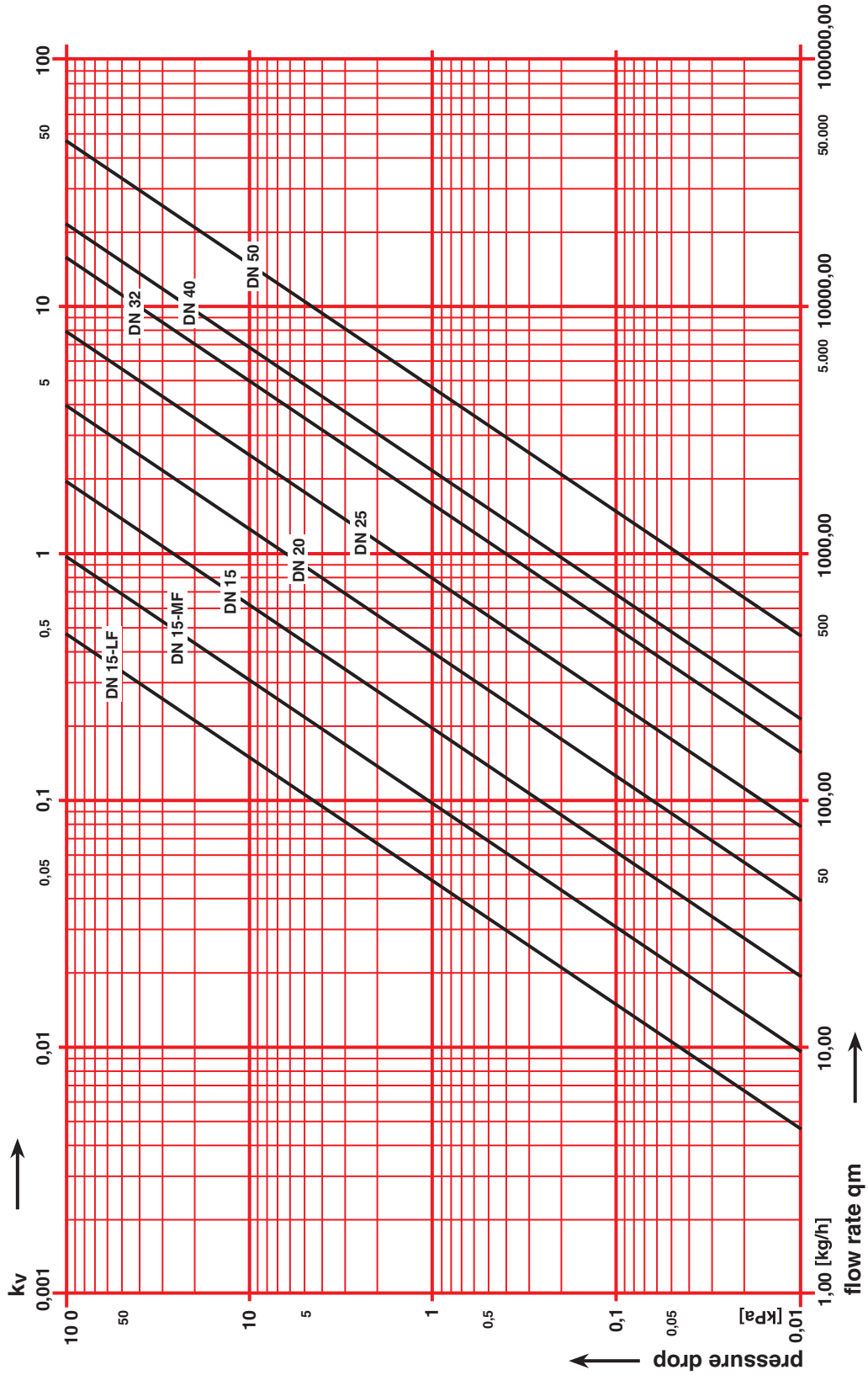

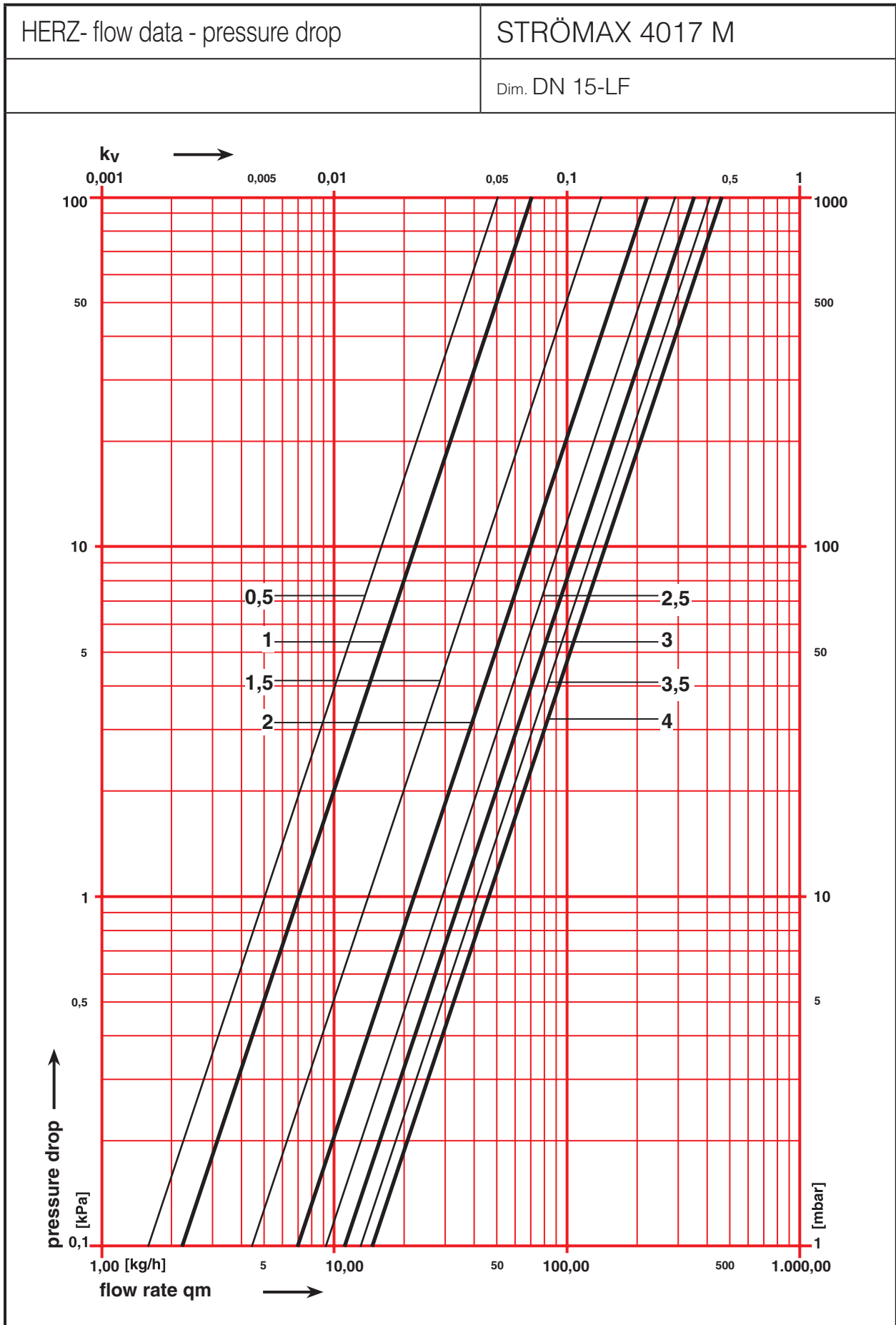

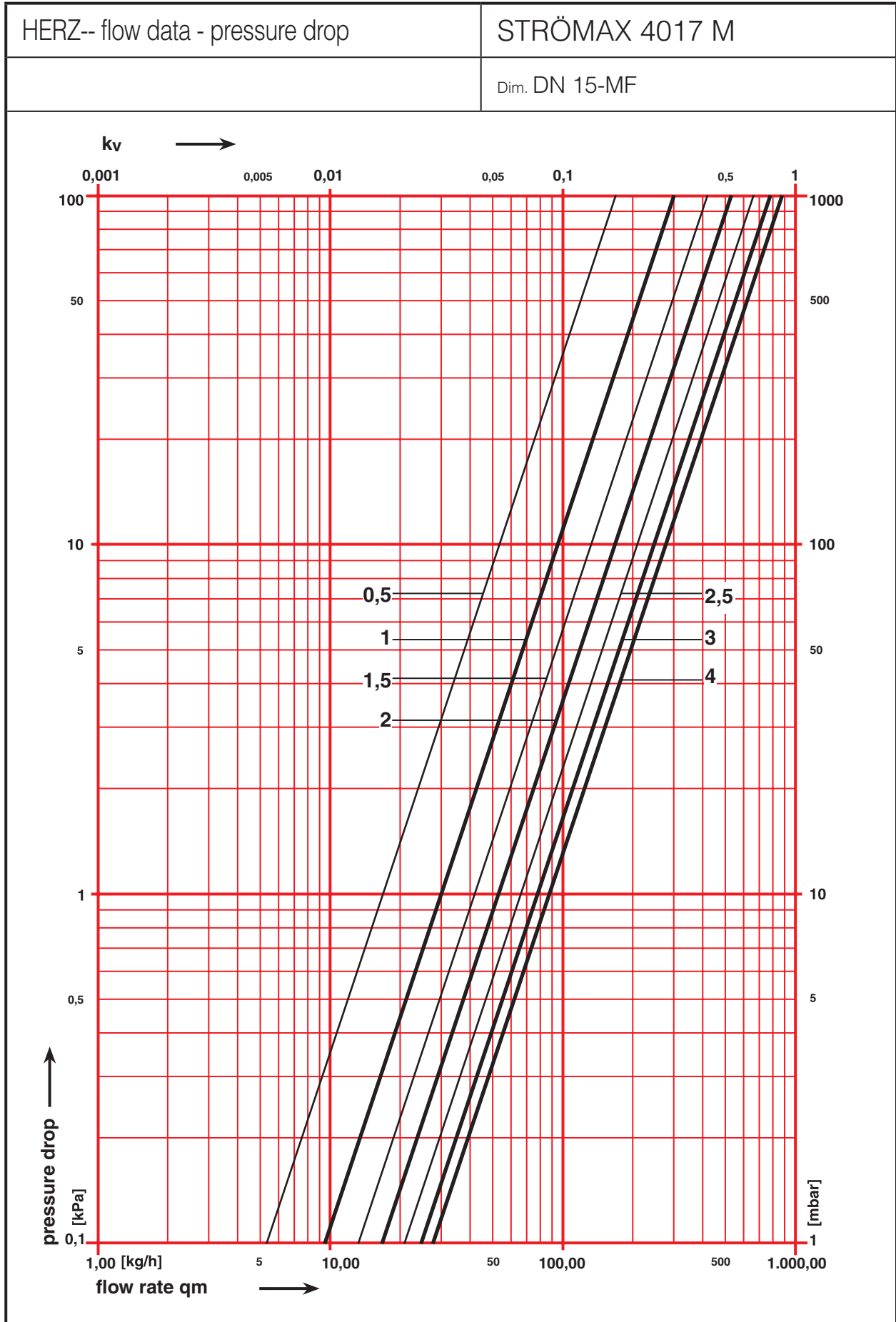

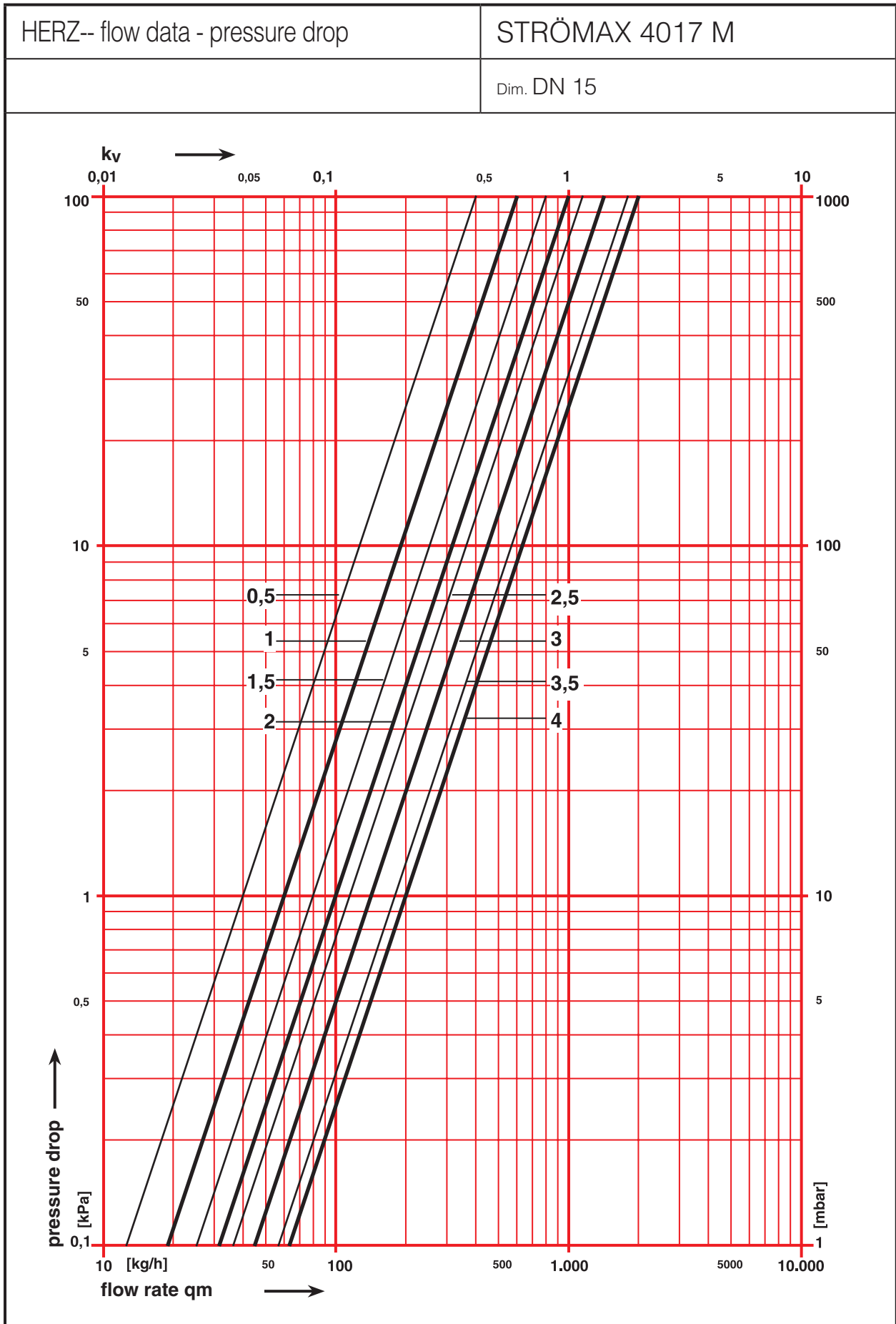

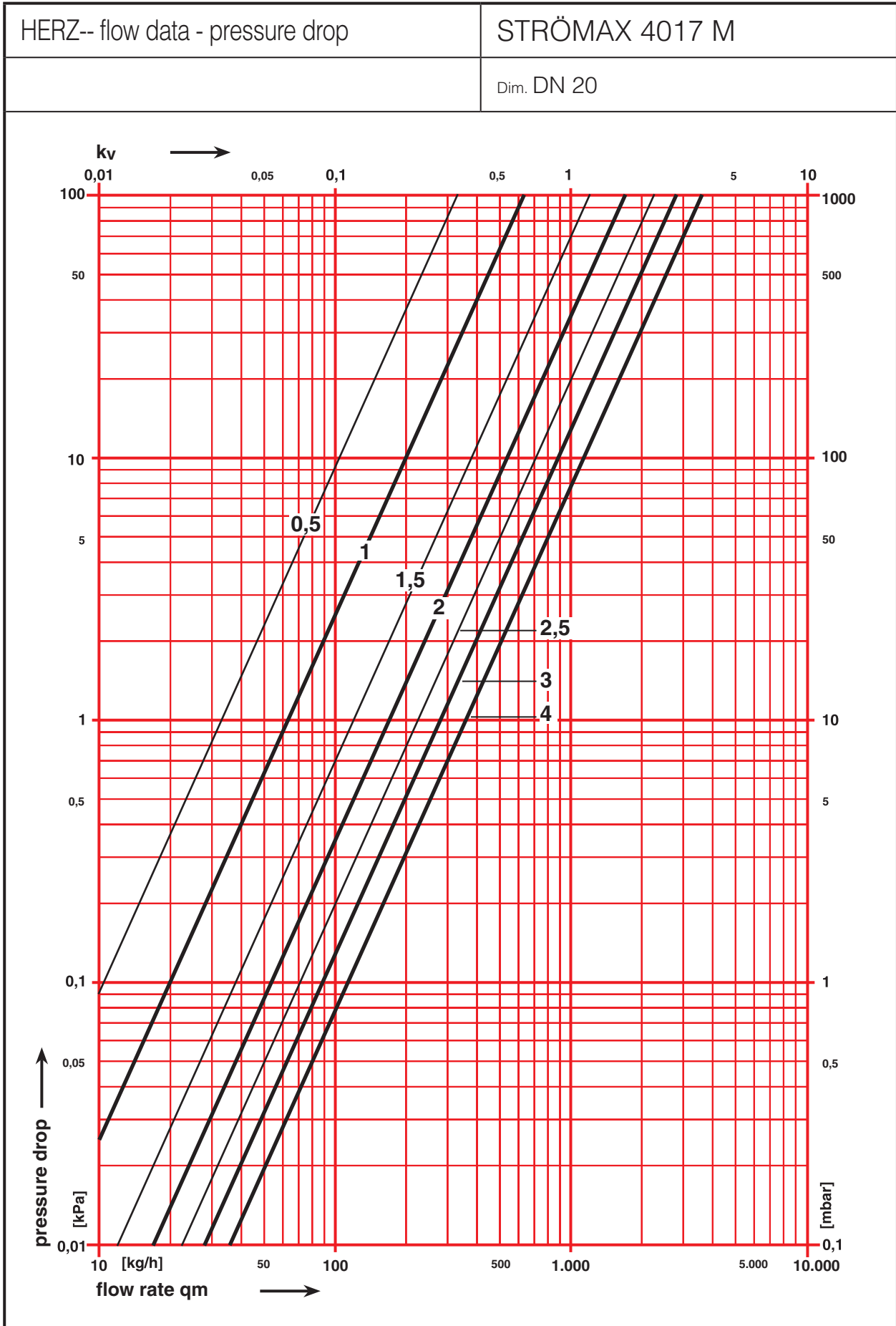

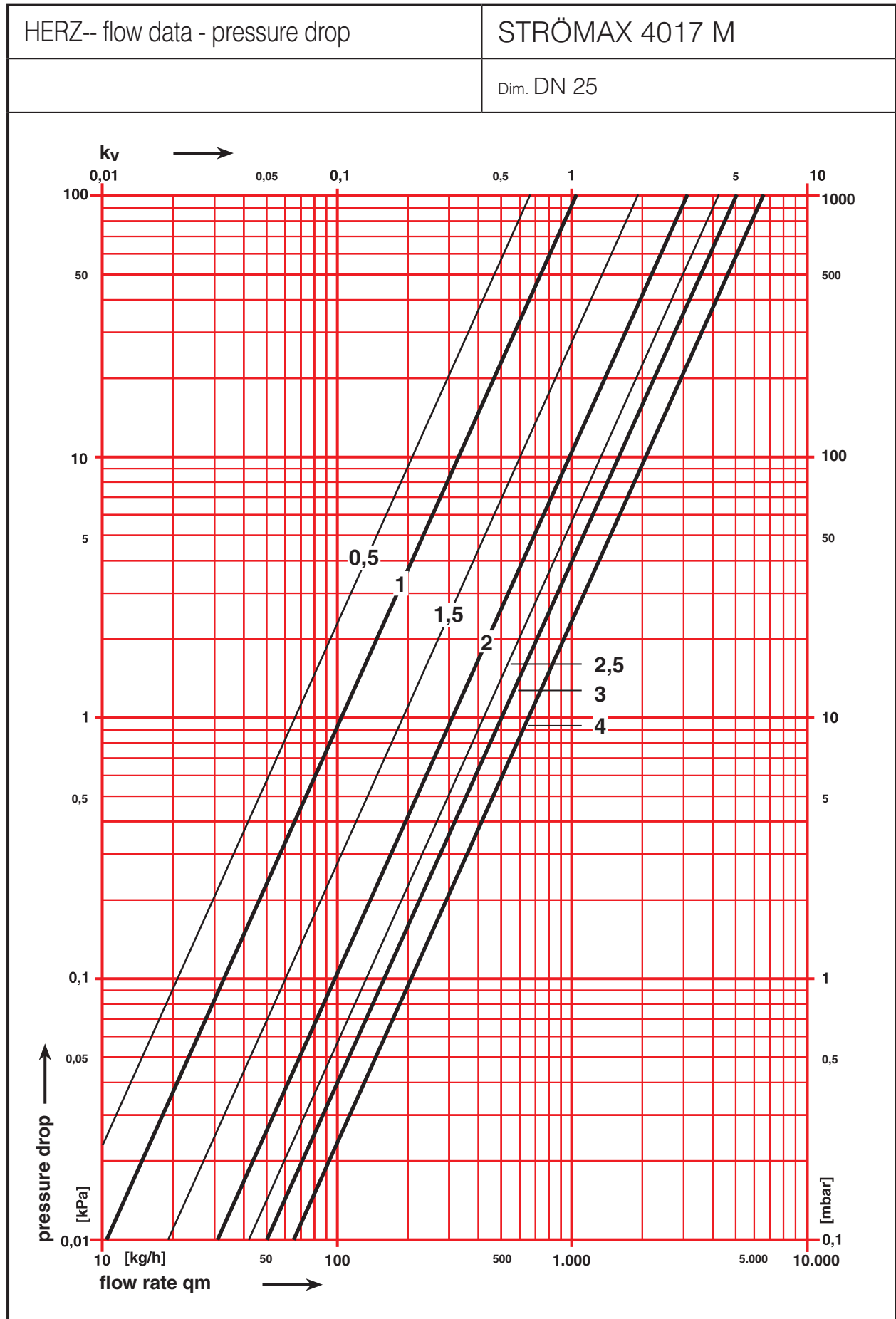

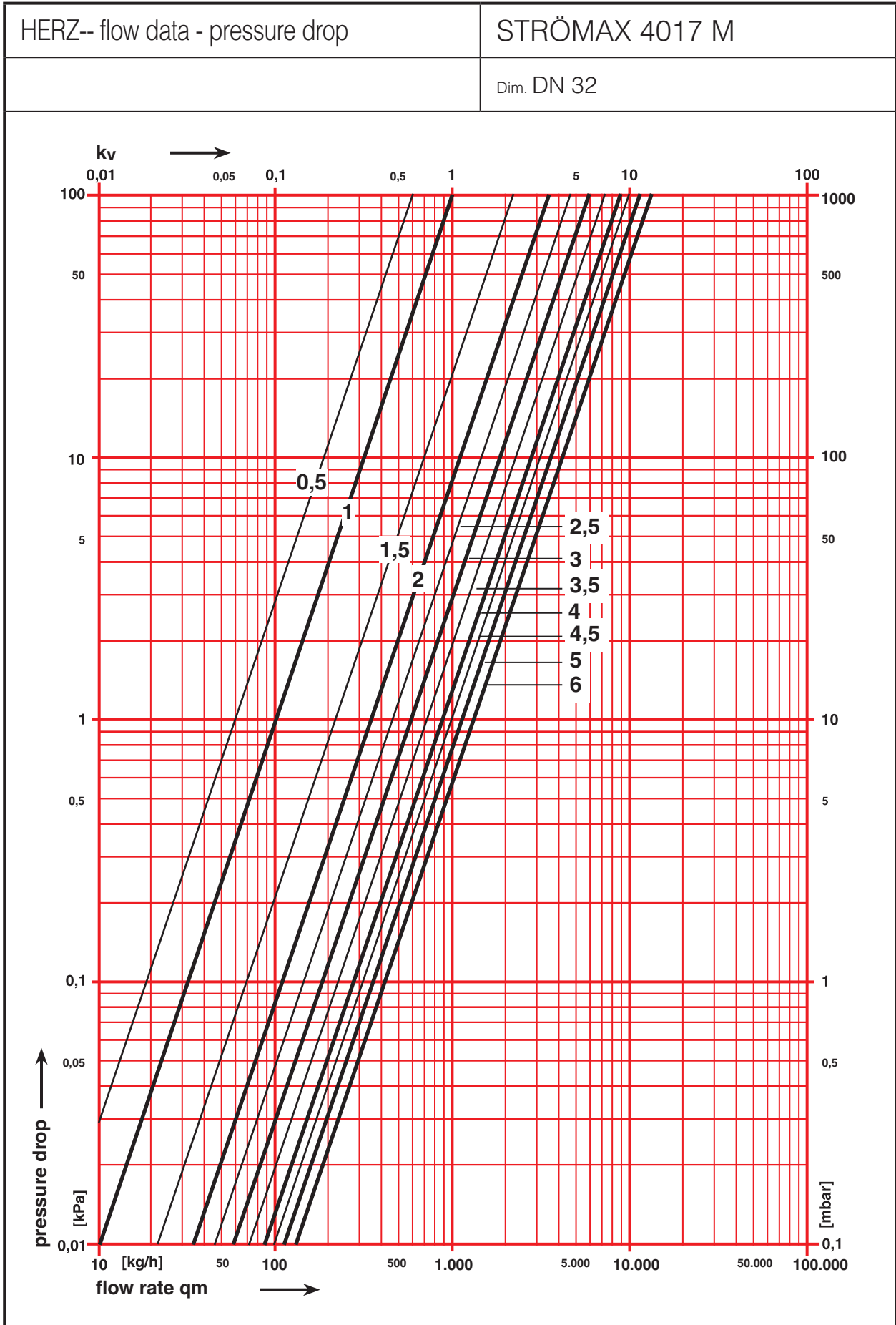

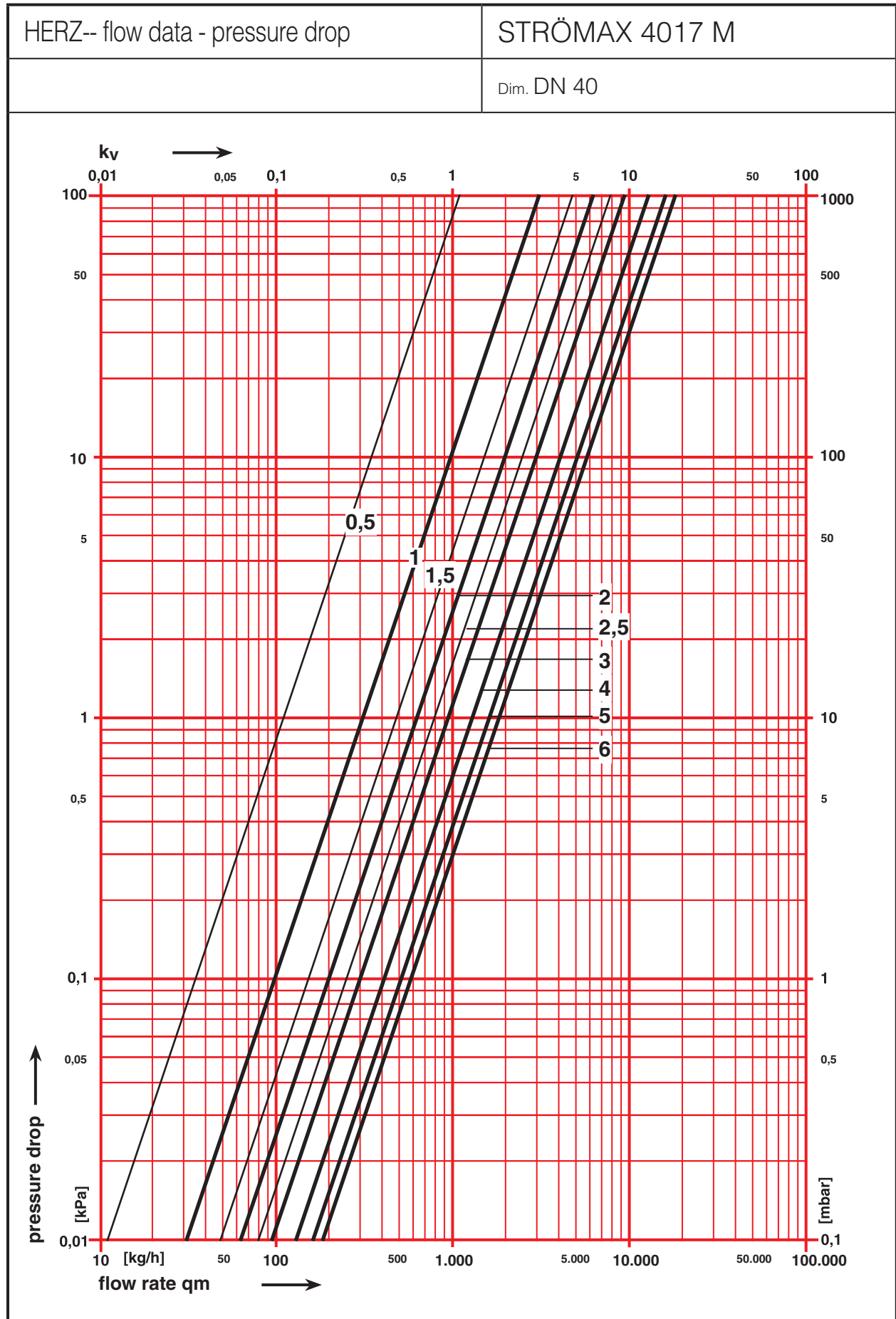

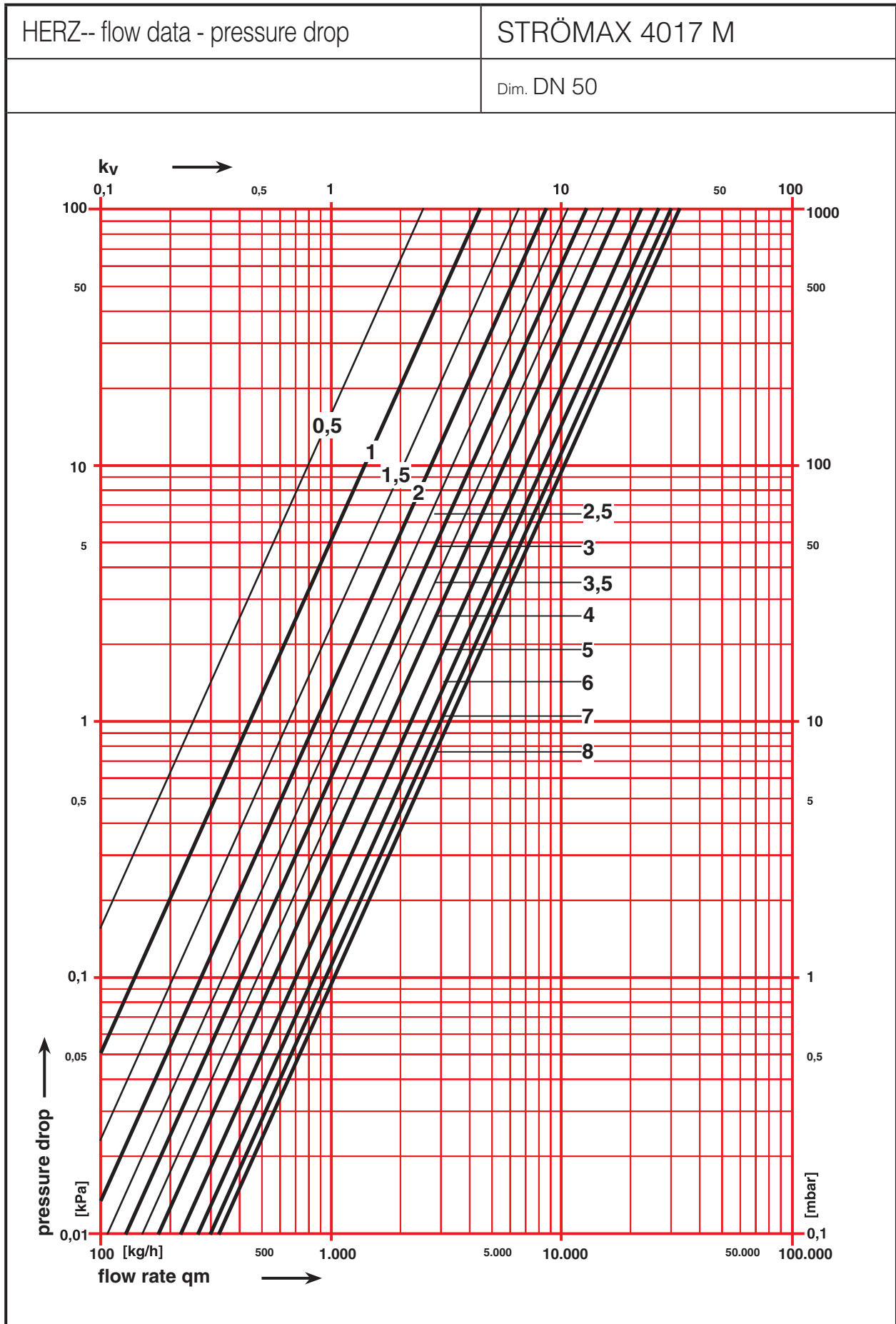

HERZ STRÖMAX 4017 M

DN	15	15-LF	15-MF	20	25	32	40	50
$k_{V_{max}}$	2	0,46	0,88	3,6	6,5	13,3	18,5	33
k_{Vs}	1,95	0,48	0,97	3,95	7,9	15,75	21,5	46,7
Position	k_v	k_v	k_v	k_v	k_v	k_v	k_v	k_v
0,5	0,40	0,05	0,17	0,33	0,66	0,60	1,10	2,55
0,6	0,43	0,05	0,19	0,38	0,70	0,66	1,45	2,85
0,7	0,46	0,06	0,21	0,43	0,74	0,72	1,80	3,15
0,8	0,49	0,06	0,23	0,48	0,78	0,78	2,15	3,45
0,8	0,52	0,06	0,25	0,53	0,82	0,84	2,50	3,75
0,9	0,56	0,07	0,27	0,58	0,86	0,90	2,85	4,05
1,0	0,60	0,07	0,30	0,63	1,04	1,00	3,10	4,50
1,1	0,64	0,08	0,32	0,73	1,20	1,20	3,37	4,80
1,2	0,67	0,09	0,34	0,83	1,36	1,40	3,64	5,10
1,3	0,71	0,10	0,36	0,93	1,52	1,60	3,91	5,40
1,3	0,74	0,11	0,38	1,03	1,68	1,80	4,18	5,70
1,4	0,78	0,12	0,40	1,13	1,84	2,00	4,45	6,00
1,5	0,81	0,14	0,42	1,20	1,90	2,20	4,80	6,60
1,6	0,85	0,16	0,44	1,28	2,10	2,40	5,04	6,95
1,7	0,88	0,17	0,45	1,36	2,30	2,60	5,28	7,30
1,8	0,92	0,19	0,47	1,44	2,50	2,80	5,52	7,65
1,8	0,95	0,20	0,48	1,52	2,70	3,00	5,76	8,00
1,9	0,97	0,22	0,50	1,60	2,90	3,20	6,00	8,35
2,0	1,00	0,22	0,53	1,70	3,10	3,50	6,30	8,70
2,1	1,04	0,23	0,55	1,80	3,25	3,70	6,58	9,05
2,2	1,07	0,24	0,57	1,90	3,40	3,90	6,86	9,40
2,3	1,11	0,25	0,59	2,00	3,55	4,10	7,14	9,75
2,3	1,14	0,26	0,61	2,10	3,70	4,30	7,42	10,10
2,4	1,18	0,27	0,63	2,20	3,85	4,50	7,70	10,45
2,5	1,20	0,29	0,66	2,25	4,20	4,65	7,90	10,80
2,6	1,22	0,30	0,68	2,35	4,32	4,85	8,18	11,10
2,7	1,24	0,30	0,70	2,45	4,44	5,05	8,46	11,40
2,8	1,26	0,31	0,72	2,55	4,56	5,25	8,74	11,70
2,8	1,28	0,32	0,74	2,65	4,68	5,45	9,02	12,00
2,9	1,30	0,33	0,76	2,75	4,80	5,65	9,30	12,30
3,0	1,42	0,35	0,78	2,80	5,00	5,90	9,50	13,00
3,1	1,49	0,36	0,79	2,86	5,07	6,13	9,78	13,40
3,2	1,56	0,37	0,80	2,92	5,14	6,36	10,06	13,80
3,3	1,63	0,37	0,81	2,98	5,21	6,59	10,34	14,20
3,3	1,70	0,38	0,82	3,04	5,28	6,82	10,62	14,60
3,4	1,77	0,39	0,83	3,10	5,35	7,05	10,90	15,00
3,5	1,80	0,41	0,86	3,25	5,80	7,25	11,20	15,30
3,6	1,83	0,42	0,86	3,32	5,93	7,50	11,50	15,70
3,7	1,85	0,42	0,87	3,39	6,06	7,75	11,80	15,90
3,8	1,88	0,43	0,87	3,46	6,19	8,00	12,10	16,20
3,8	1,90	0,43	0,87	3,53	6,32	8,25	12,40	16,50
3,9	1,93	0,44	0,88	3,60	6,45	8,50	12,70	16,80
4,0	2,00	0,46	0,88	3,60	6,50	8,85	13,00	18,00
4,1						8,96	13,30	18,35

DN	15	15-LF	15-MF	20	25	32	40	50
$k_{v\ max}$	2	0,46	0,88	3,6	6,5	13,3	18,5	33
k_{vs}	1,95	0,48	0,97	3,95	7,9	15,75	21,5	46,7
Position	k_v	k_v	k_v	k_v	k_v	k_v	k_v	k_v
4,2						9,07	13,60	18,70
4,3						9,18	13,90	19,05
4,3						9,29	14,20	19,40
4,4						9,40	14,50	19,75
4,5						9,90	14,70	20,20
4,6						10,15	14,95	20,55
4,7						10,40	15,20	20,90
4,8						10,65	15,45	21,25
4,8						10,90	15,70	21,60
4,9						11,15	15,95	21,95
5,0						11,40	16,25	22,50
5,1						11,60	16,40	22,90
5,2						11,80	16,55	23,30
5,3						12,00	16,70	23,70
5,3						12,20	16,85	24,10
5,4						12,40	17,00	24,50
5,5						12,50	17,40	25,00
5,6						12,63	17,60	25,30
5,7						12,76	17,80	25,60
5,8						12,89	18,00	25,90
5,8						13,02	18,20	26,20
5,9						13,15	18,40	26,50
6,0						13,30	18,50	26,70
6,1								26,98
6,2								27,26
6,3								27,54
6,3								27,82
6,4								28,10
6,5								28,60
6,6								28,93
6,7								29,26
6,8								29,59
6,8								29,92
6,9								30,25
7,0								30,30
7,1								30,55
7,2								30,80
7,3								31,05
7,3								31,30
7,4								31,55
7,5								31,90
7,6								32,10
7,7								32,30
7,8								32,50
7,8								32,70
7,9								32,90
8,0								33,00

