

HERZ differential pressure overflow valve

Data sheet for **4004**, Issue 0912

☑ Models

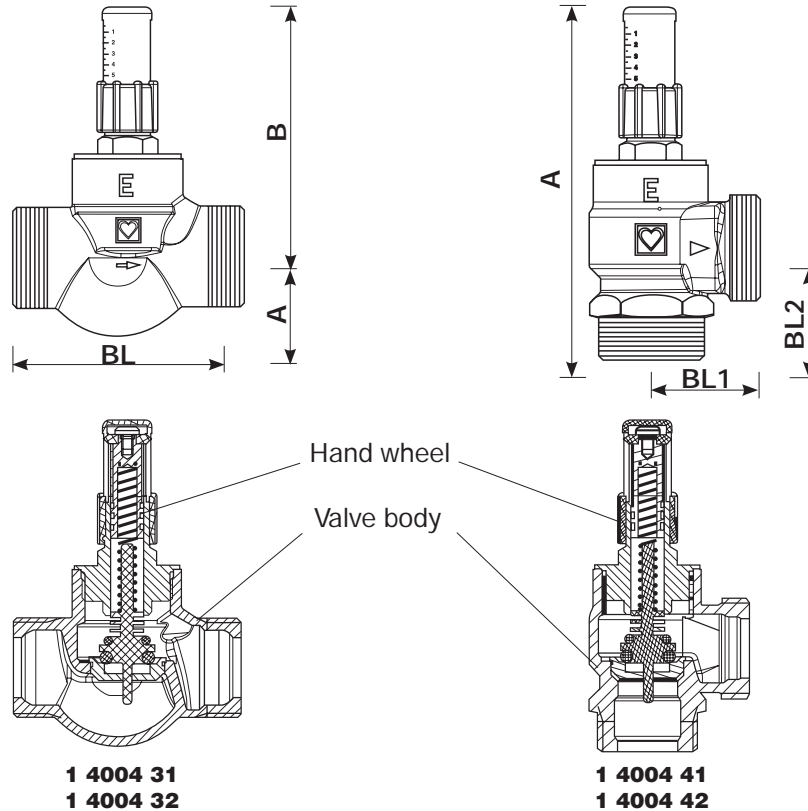

Order number	1 4004 31	1 4004 32	1 4004 41	1 4004 42
Dimension	DN 15	DN 20	DN 15	DN 20
Model	Straight model	Straight model	Angle model	Angle model
Threaded connection	G 3/4 B ISO 228/1	G 1 B ISO 228/1	G 3/4 B ISO 228/1	G 1 B ISO 228/1
A	26	26	101	111
B	82	82	-	-
BL	69,5	75	-	-
BL1	-	-	32	34
BL2	-	-	25	34,5

- 1 4004 31 **HERZ** - Differential pressure overflow valve, straight model, DN 15, nickel-plated, screw connection G 3/4 B ISO 228/1 kvs = 2,2 m³/h
- 1 4004 32 **HERZ** - Differential pressure overflow valve, straight model, DN 20, nickel-plated, screw connection G 1 B ISO 228/1 kvs = 2,2 m³/h
- 1 4004 41 **HERZ** - Differential pressure overflow valve, angle model, DN 15, nickel-plated, screw connection G 3/4 B ISO 228/1 kvs = 2,2 m³/h
- 1 4004 42 **HERZ** - Differential pressure overflow valve, angle model, DN 20, nickel-plated, screw connection G 1 B ISO 228/1 kvs = 2,2 m³/h

☑ Technical data

Maximum operating temperature 120 °C Minimum operating temperature 0 °C
 Maximum operating pressure 10bar
 Differential pressure, factory setting Setting range of 1
 Differential pressure can be set Set range 0,5 - 5 kPa
 Heating water quality in accordance with ÖNORM H 5195 and/or VDI guideline 2035.

☑ Application area

In hot water heating systems, between flow and return to avoid undesired high differential pressure.

☑ Application

The differential pressure overflow valve is used in cases when, during pipe sizing or pump calculations, it is not possible to keep the differential pressure low or to avoid a high differential pressure for the thermostatic valves.

According to VDMA recommendations, the piping of thermostatic valves has to be affected with a differential pressure of 0.05 bar. It must be ensured that the differential pressure on valves located near to the pump or when the flow rate becomes low does not exceed 0.2 bar. Higher differential pressures can cause noise and detrimentally affect the operation and life of the valves.

Additionally, the differential pressure overflow valve preserves a minimum quantity of circulation water.

Please ensure during construction that when the differential pressure of the overflow valve is set, the water quantity necessary to reduce the differential pressure is by-passed (dependent on the over sizing of the pump and the slope of the pump characteristic).

If the achievable overflow water quantity (according to the nomograph) is too low, a second overflow valve must be installed. The bypass piping should be as short as possible and with low pressure loss.

☑ Structural Characteristics

- Brass bodies where valve cone and valve cone are located
- Setting by means of a hand wheel, and the set value can be read directly on the scale
- Connection with flat seal with two pipe threads
- The valve can be demounted at any time using the flat seal
- Vibration-free operation with low noise due to the special layout of the valve cone
- Vibration dampers prevent pulsating noise in the event of a sudden full opening of the valve cone

☑ Materials

Body:	Brass CuZn40Pb2
Internal parts:	Plastic
Spring:	Stainless steel
Hand wheel:	Plastic
Joint elements:	EPDM

☑ Mounting example

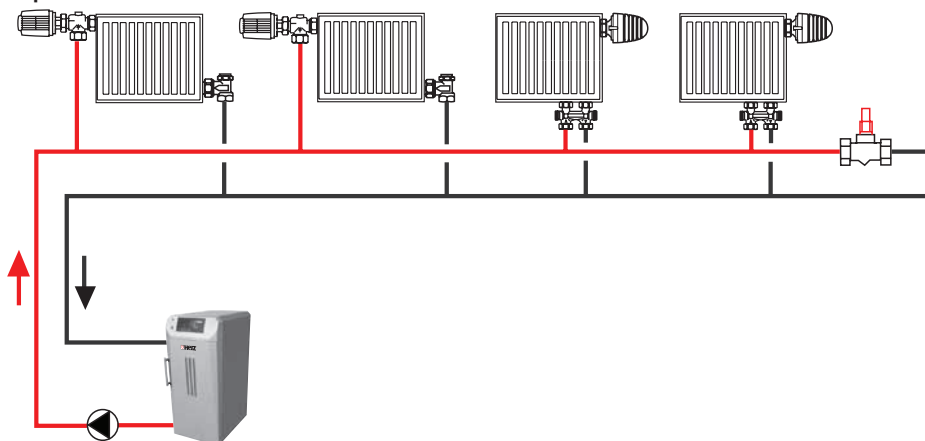

☑ Accessories

- 1 6220 12 Screw connection with flat seal 3/4
- 1 6220 22 Screw connection with flat seal 3/4 x 44 mm
- 1 6221 02 Screw connection, reduced 3/4 x 1/2
- 1 6236 02 Soldering connection 3/4 x 15 mm
- 1 6236 12 Soldering connection 3/4 x 18 mm
- 1 6236 22 Soldering connection 3/4 x 22 mm
- 1 6240 02 Welding connection 3/4 x 26.9 mm
- 1 6241 02 Welding connection, reduced 3/4 x 21.3 mm
- 1 6220 63 Screw connection 1
- 1 6236 63 Soldering connection 1 x 28 mm
- 1 6240 63 Welding connection 1 x 33.7 mm

4004 dp / Q-Diagramm

