

HERZ-Regulating valve 4001

Flow rate controller

Data sheet 4001, Issue 1011

Dimensions in mm

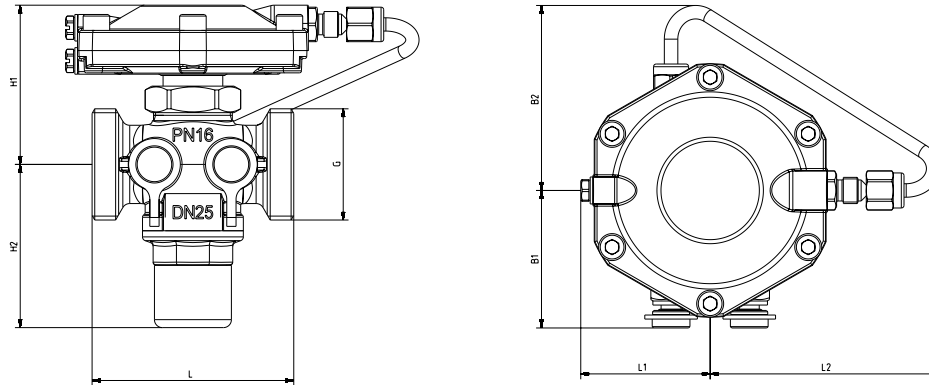

	DN	G	L	H1	H2	B1	B2	L1	L2
1 4001 21	15	3/4 G	66	59	61,5	49	63	48	81
1 4001 22	20	1 G	76	60	61,5	51	68,5	48	85
1 4001 23	25	1 1/4 flatsealing	76	60	61,5	51	68,5	48	85
1 4001 24	32	1 1/2 flatsealing	114	76	79	76	47	57	89
1 4001 25	40	1 3/4 flatsealing	132	86	90	75	47	70	81
1 4001 26	50	2 3/8 flatsealing	140	86	90	75	47	70	81

Technical data

max. operating pressure	16 bar
max. differential pressure on the body	4 bar
min. operating temperature	2 °C (pure water)
min. operating temperature	- 20 °C (frost protection)
max. operating temperature	up to DN 32 130 °C from DN 40 110 °C

Application

The Pressure Independent Balancing Valve (PIBV) is used in all heating and cooling systems with circulation pumps. The valve automatically maintains flow to the required part of the system at the set rate by measuring and immediately adjusting to any variation in pressure. No additional measurements are necessary and the correct flow rate is achieved at all operating conditions. The diaphragm responds to the pressure upstream and downstream of the regulating valve (via an internal impulse line). The valve settings directly affect the volumetric flow through the valve. It is thus possible to set the maximum flow rate based on the flow chart when the valve is fitted. This allows for the balancing of heating circuits, cooling water systems, ceiling cooling and heating panels, air heaters, etc. without any need to first assess the pressure variations in the system. In addition to the PIBV, HERZ Ball Valves (2190) can be fitted in the corresponding flow pipe. If control measurements of the flow rate are required, then STRÖMAX-M valves (4017 M, 4117 M, 4217 GM) must be fitted instead.

Materials

Body: dezincification-resistant brass
 Membranes and O-rings: EPDM
 Water purity in accordance with the ÖNORM H 5195 and VDI 2035 standards
 Ethylene and propylene glycol can be mixed to a ratio of 15 - 45 vol. [%].

☑ Installation

The PIBV is fitted in the return in any orientation. The arrow on the valve body should align with the direction of flow.

It is recommended that an isolation valve is fitted both upstream and downstream of the PIBV.

The PIBV may be isolated using the HERZ pre-setting key (1 4006 02).

For pre-setting, turn the key right (clockwise) up to the stop. The setting should then read < 0%.

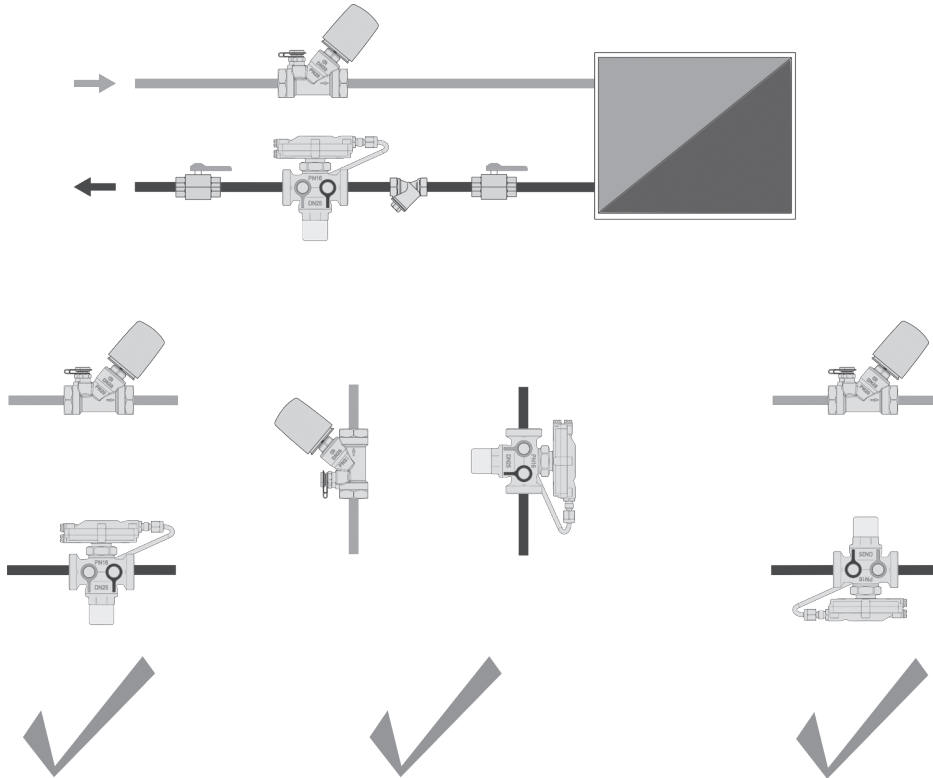

☑ kvs-values

DN 15	0,4 m ³ /h	DN 32	2,5 m ³ /h
DN 20	0,9 m ³ /h	DN 40	5 m ³ /h
DN 25	1,9 m ³ /h	DN 50	5 m ³ /h

☑ Accessories and spare parts

- 7217 HERZ-Motorised balancing valve, angle version
- 4117 HERZ-STRÖMAX circuit control valves, angle version
- 4217 HERZ-STRÖMAX circuit control valves, straight version
- 4017 HERZ-STRÖMAX circuit control valves with integrated metering orifice plate
- 4125 HERZ shut-off valves, angle version
- 4115 HERZ shut-off valves, angle version
- 4215 HERZ shut-off valves, straight version, also variants with male threads. For details please refer to the corresponding data sheets.

- 1 0284 01 test point for HERZ circuit control valve, blue cap (return)
- 1 0284 02 test point for HERZ circuit control valve, red cap (flow)
- 1 0284 11 test point for HERZ circuit control valve, extended model, blue cap (return)
- 1 0284 12 test point for HERZ circuit control valve, extended model, red cap (flow)
- 1 0284 21 HERZ test point with draining function, blue cap (return)
- 1 0284 22 HERZ test point with draining function, red cap (flow)
- 1 0284 00 test point adapter set
- 1 7709 .. HERZ actuating drive for two-point or pulse control
- 1 7990 .. HERZ actuating drive for continuous control
- 1 0273 09 screw plug 1/4
- 1 4006 02 HERZ pre-setting key for flow rate controller

Pipe connections (with cone seal) for metal pipes

Pipe		8	10	12	14	15	16	18	22
Valve		DN 15	DN 15	DN 15	DN 15	DN 15	DN 15	DN 15	DN 20
Nut G		3/4	3/4	3/4	3/4	3/4	3/4	3/4	1
Connection	with metallic seal	1 6274 18	1 6274 00	1 6274 01	1 6274 02	1 6274 03	1 6274 04	–	1 6273 01
Connection	with soft seal	–	–	1 6276 12	1 6276 14	1 6276 15	1 6276 16	1 6276 18	–

Compression union for calibrated soft steel and copper pipes (for details please refer to the corresponding data sheets)

 Pipe connections (with cone seal) for plastic pipes

Pipe	10 x 1,3	14 x 2	15 x 2,5	16 x 2	16 x 2,2	17 x 2	17 x 2,5	18 x 2,5	18 x 2
Valve	DN 15	DN 15	DN 15	DN 15	DN 15	DN 15	DN 15	DN 15	DN 15
Nut G	3/4	3/4	3/4	3/4	3/4	3/4	3/4	–	1
Connection	1 6098 18	1 6098 02	1 6098 16	1 6098 03	1 6098 12	1 6098 04	1 6098 05	1 6098 06	1 6098 07

Pipe	20 x 2	20 x 3,5	20 x 2,5	25 x 3,5	26 x 3
Valve	DN 15	DN 15	DN 15	DN 15	DN 15
Nut G	3/4	3/4	3/4	1	1
Connection	1 6098 08	1 6098 10	1 6098 11	1 6198 00	1 6198 01
Valve	DN 15				
Nut G	1				
Connection	1 6198 12				

Plastic pipe connections for PE-X, PB and aluminium composite pipes (for details please refer to the corresponding data sheets)

When installing soft steel or copper pipes with a pipe wall of 1 mm or less with compression unions, we recommend the use of support sleeves (order no.: 1 0674 xx). When installing plastic pipes, suitable calibration tools are needed. Please refer to our instruction manual. For proper installation use silicone oil to lubricate the thread of the locking nut or olive screw as well as the olive.

 Connection elements

- 1 6220 .. Iron pipe connection, consisting of nut, seal and pipe nipple with male pipe thread
- 1 6236 .. Soldering connection, consisting of nut, seal and soldering nipple
- 1 6240 .. Welding connection, consisting of nut, seal and welding nipple
- 1 6210 .. Iron pipe connection consisting of nut, seal and pipe nipple with male pipe thread
- 1 6235 .. Soldering connection, consisting of nut, seal and soldering nipple

☑ HERZ-Connection elements

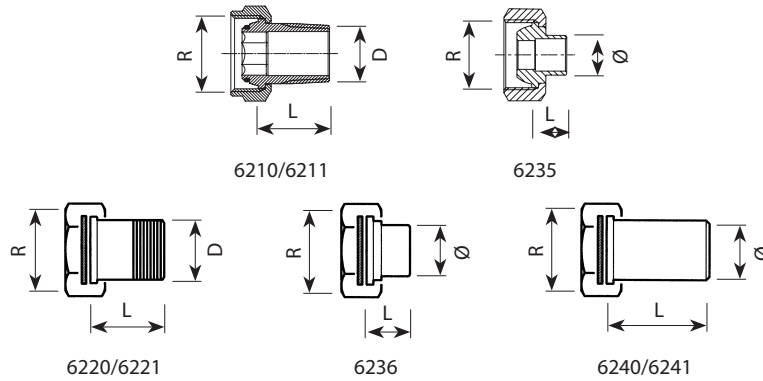

Valve dimension	Order number	R	D	ø	L
DN 15	1 6210 21	3/4	1/2	-	25
DN 15	1 6210 26	3/4	1/2	-	21
DN 15	1 6210 11	3/4	1/2	-	30
DN 15	1 6211 00	3/4	3/8	-	24
DN 20	1 6210 02	1	3/4	-	30
DN 20	1 6210 12	1	1/2	-	30
DN 25	1 6220 63	1¼	1	-	35
DN 32	1 6220 64	1½	1	-	40
DN 40	1 6220 65	1¾	1½	-	49
DN 50	1 6220 66	2⅜	2	-	56
DN 15	1 6235 21	3/4	-	12	13
DN 15	1 6235 31	3/4	-	15	13
DN 15	1 6235 41	3/4	-	18	18
DN 20	1 6235 12	1	-	18	18
DN 25	1 6236 63	1¼	-	28	24
DN 32	1 6236 64	1½	-	35	27
DN 40	1 6236 65	1¾	-	42	31
DN 50	1 6236 66	2⅜	-	54	37
DN 25	1 6240 63	1¼	-	34	51
DN 32	1 6240 64	1½	-	42	54
DN 40	1 6240 65	1¾	-	48	57
DN 50	1 6240 66	2⅜	-	60	60

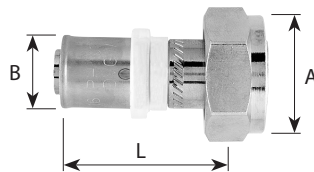

Valve dimension	Order number	A	B	L
DN 15	P 7014 81	G 3/4	14 x 2	50
DN 15	P 7016 81	G 3/4	16 x 2	50
DN 15	P 7018 81	G 3/4	18 x 2	50
DN 15	P 7020 81	G 3/4	20 x 2	50
DN 25	P 7026 43	G 1¼	26 x 3	50
DN 25	P 7032 43	G 1¼	32 x 3	50
DN 25	P 7040 43	G 1¼	40 x 3,5	70
DN 32	P 7032 44	G 1½	32 x 3	50
DN 32	P 7040 44	G 1½	40 x 3,5	70
DN 32	P 7050 44	G 1½	50 x 4	70

☑ Tips

The valves must be installed for the correct application using clean fittings. A HERZ strainer (4111) should be fitted to prevent impurities.

☑ Test points

Two test points are fitted on the same side of the valve and factory sealed. Thanks to this arrangement they are easily accessible and measurement devices can be quickly fitted, no matter in what position the valve has been installed.

☑ Pre-setting

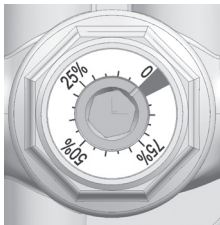

The valve setting is clearly shown in percent. The preset value can be easily adjusted. The preset PIBV can be isolated at any time or adjusted to the required flow rate.

☑ Application examples

Two-point control

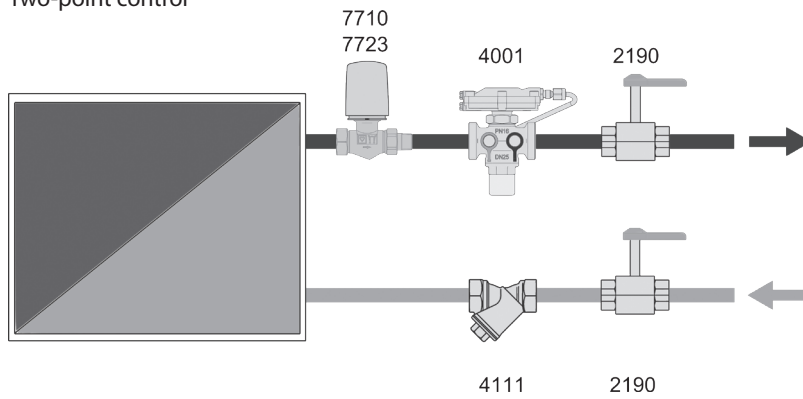

Two-point control

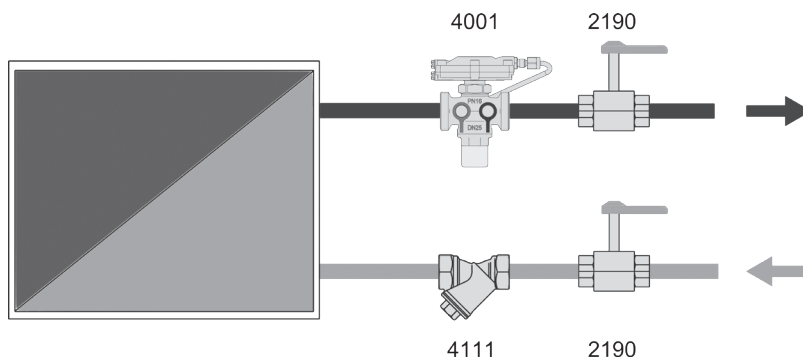

Two-point control

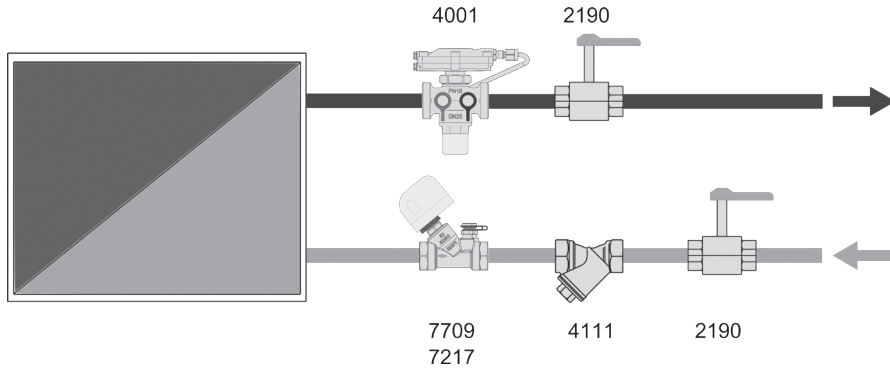

Two-point control

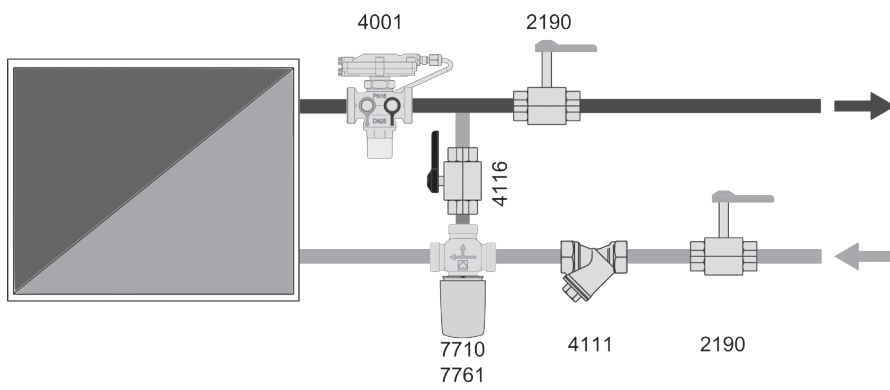

Please note: all diagrams are indicative in nature and do not claim to be complete.

